

Ministerstvo dopravy
Odbor pozemních komunikací,
příloha k č. j. MD-13449/2024-940/5.

STAVBA: OPRAVY MOSTŮ PO DIAGNOSTICKÝCH PRŮZKUMECH 2021, D6, mosty D6-060..1 a D6-060..2

STAVBA: MODERNIZACE MOSTU ev. č. 209-011a NOVÉ SEDLO

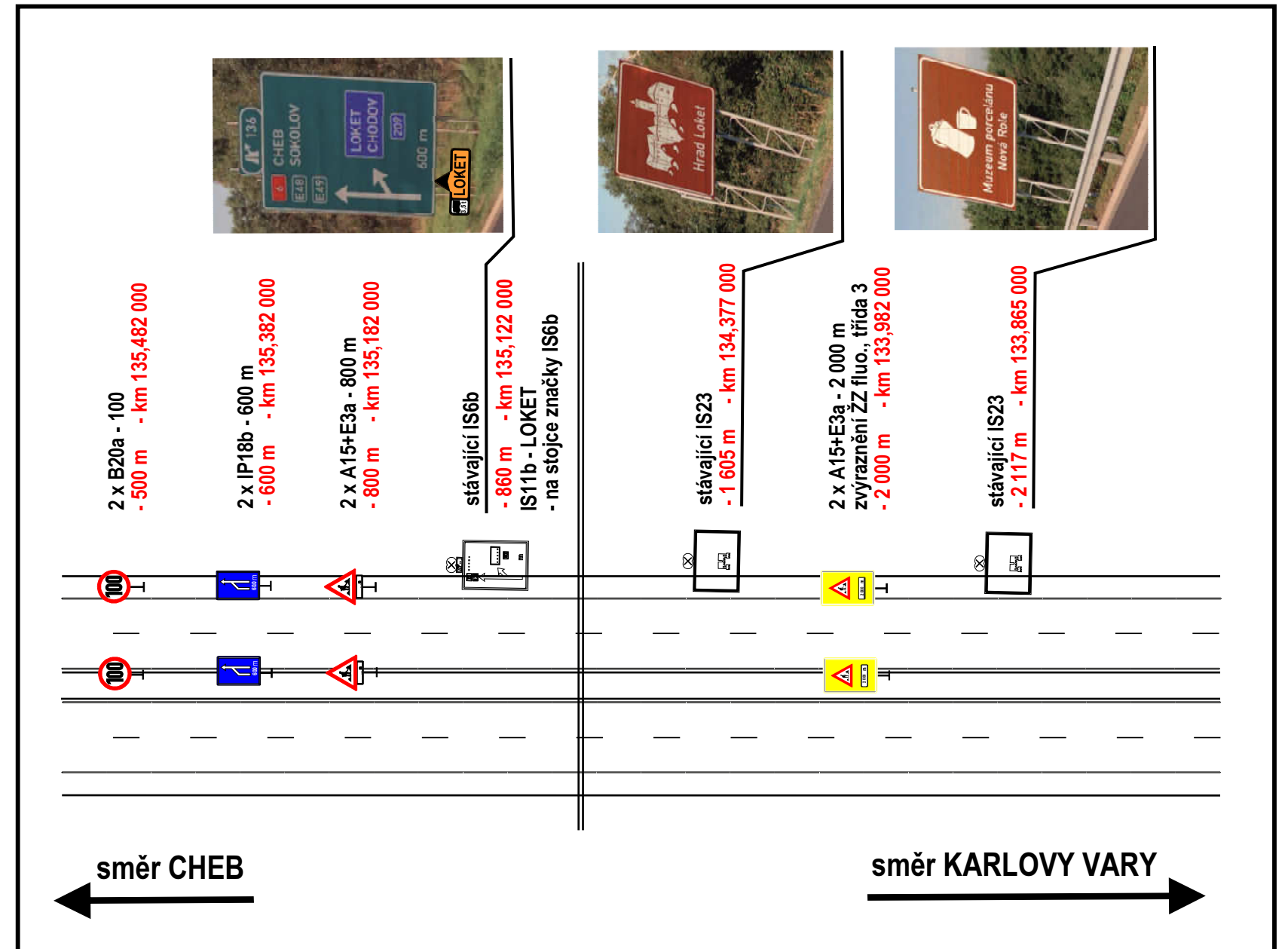
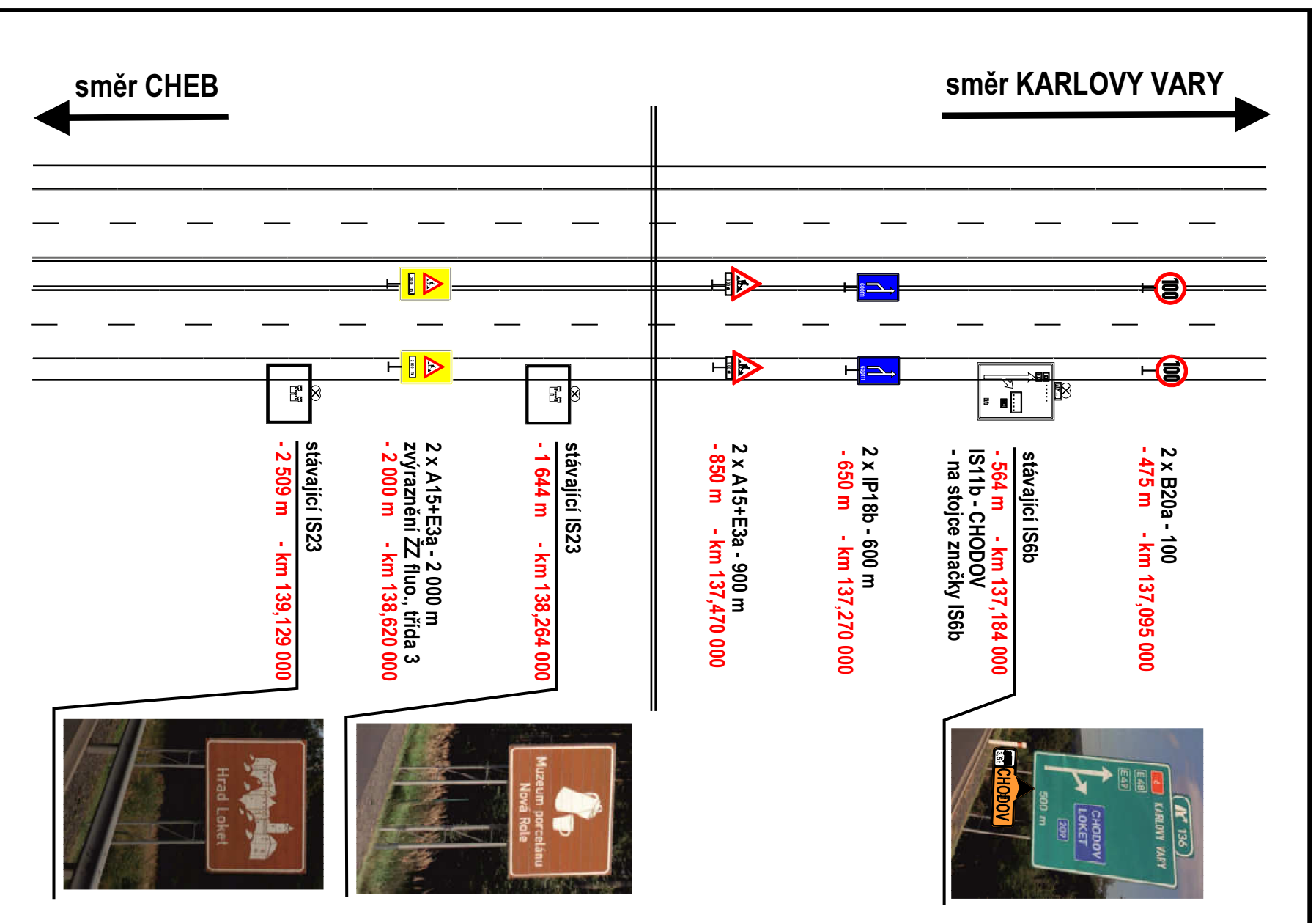
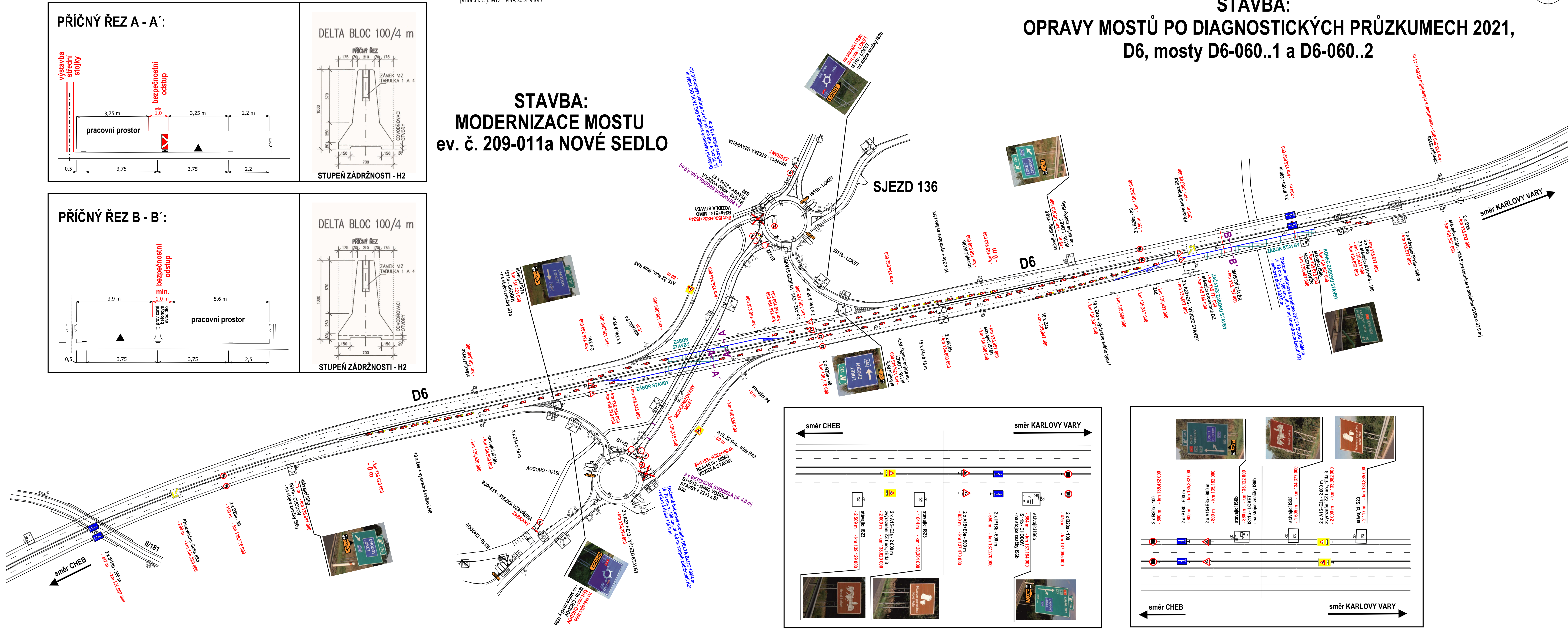
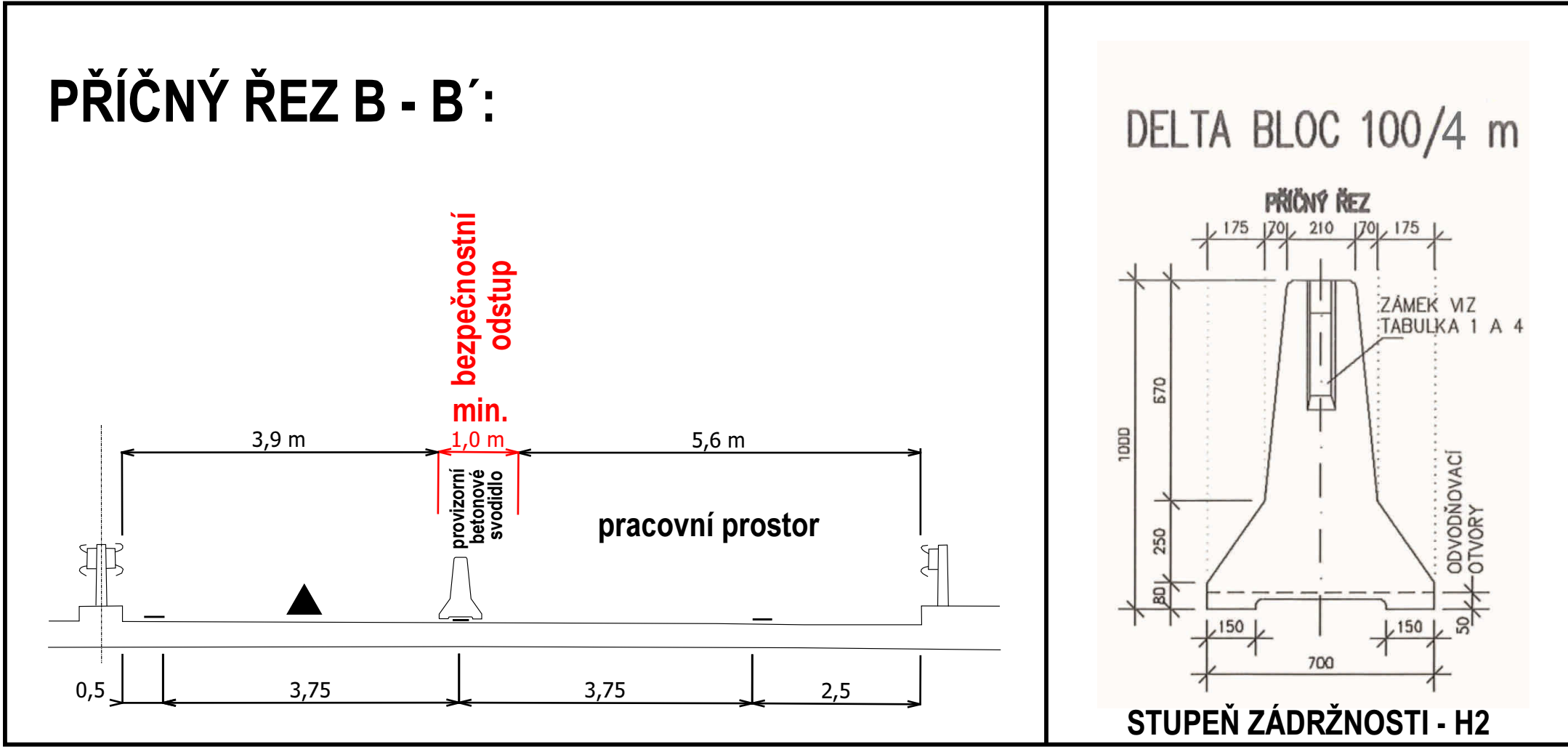
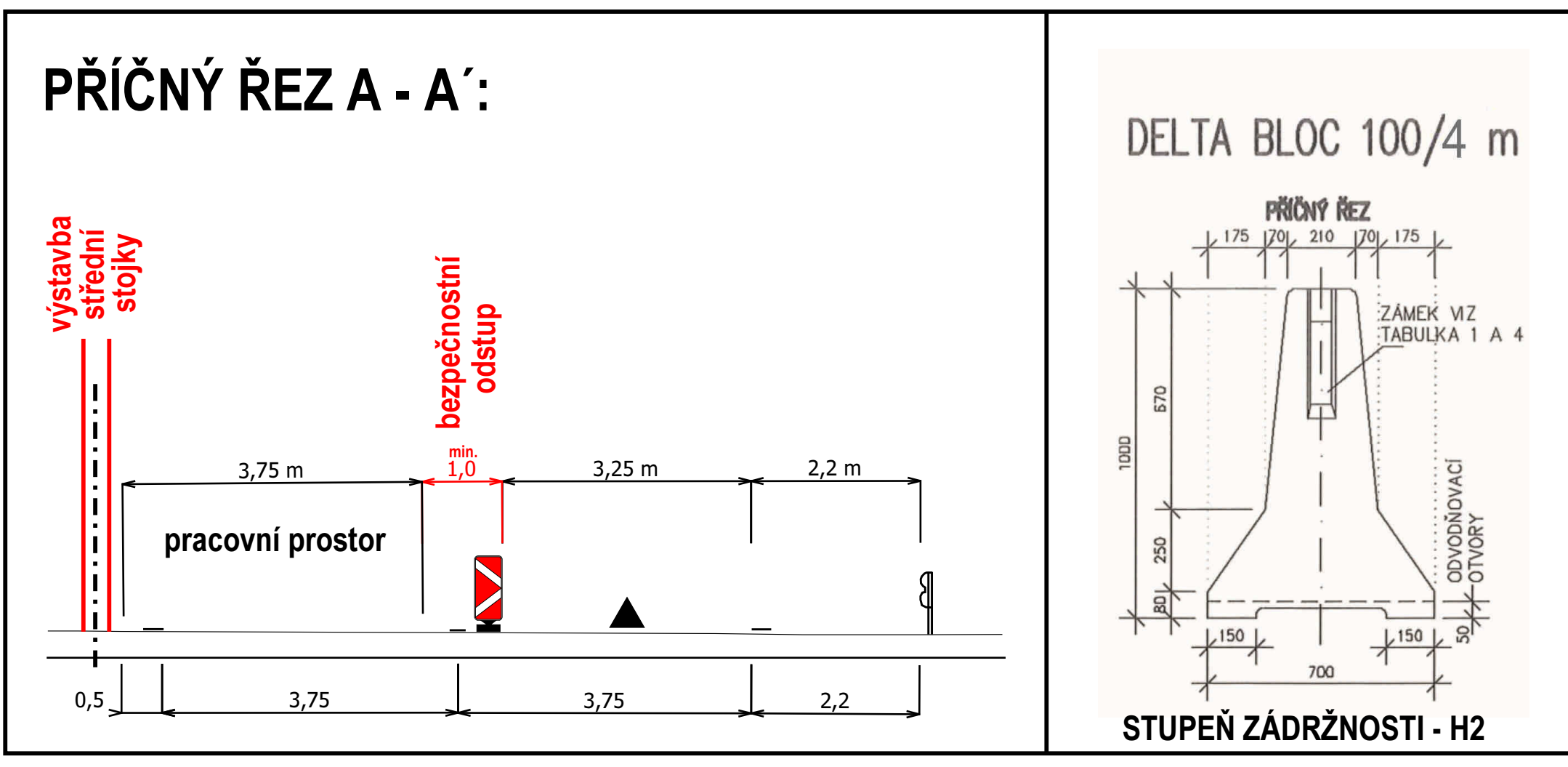

1. etapa

PROJEKTOVAL	Ing. Petr Urban	PROTRACO S.R.O. IČO: 25821401 DIČ: CZ 0802401 TEL: +420 702 119 193	Lpč. 01, 342 21 - Nápěť 02 / 2024 MĚŘÍTKO 1 : 1 250 POČET LÍSTŮ
OBJEDNATEL	Stavební firma HOBSST, a. s.		
DATUM	02 / 2024	NÁZEV AKCE MODERNIZACE MOSTU ev. č. 209-011a NOVÉ SEDLO A OPRAVY MOSTŮ PO DIAGNOSTICKÝCH PRŮZKUMECH 2021	MĚŘÍTKO ČÍSLO ZAKÁZKY
STUPEŇ PD	RDS		

0 50 m
1 : 1 300

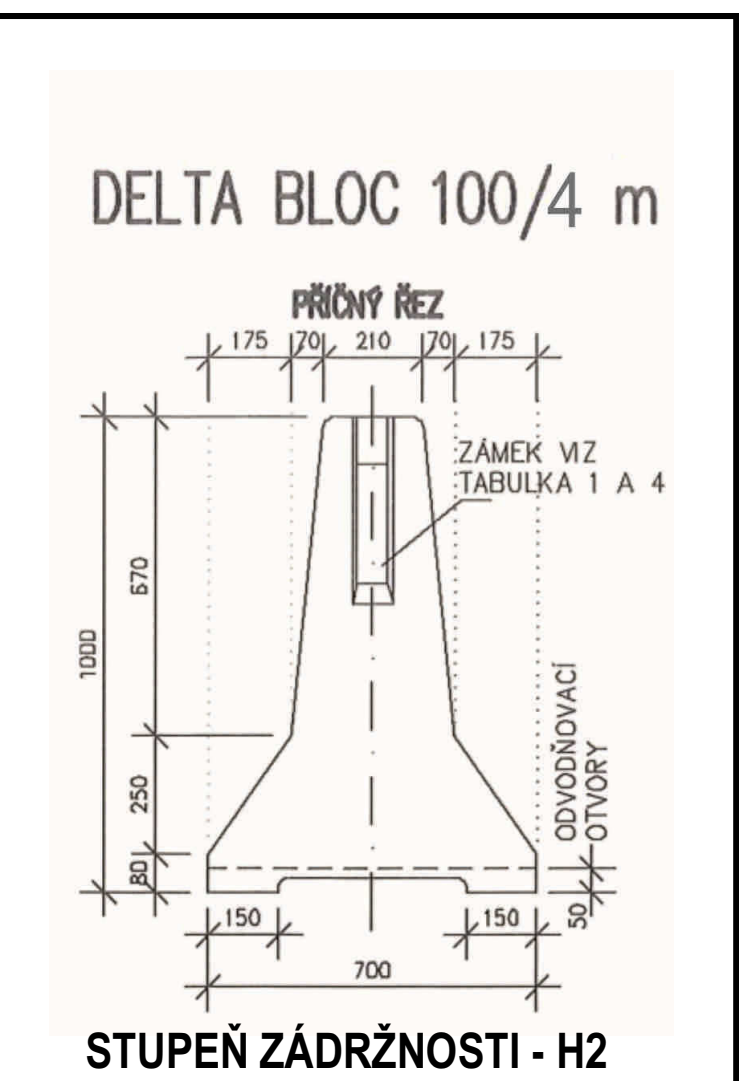
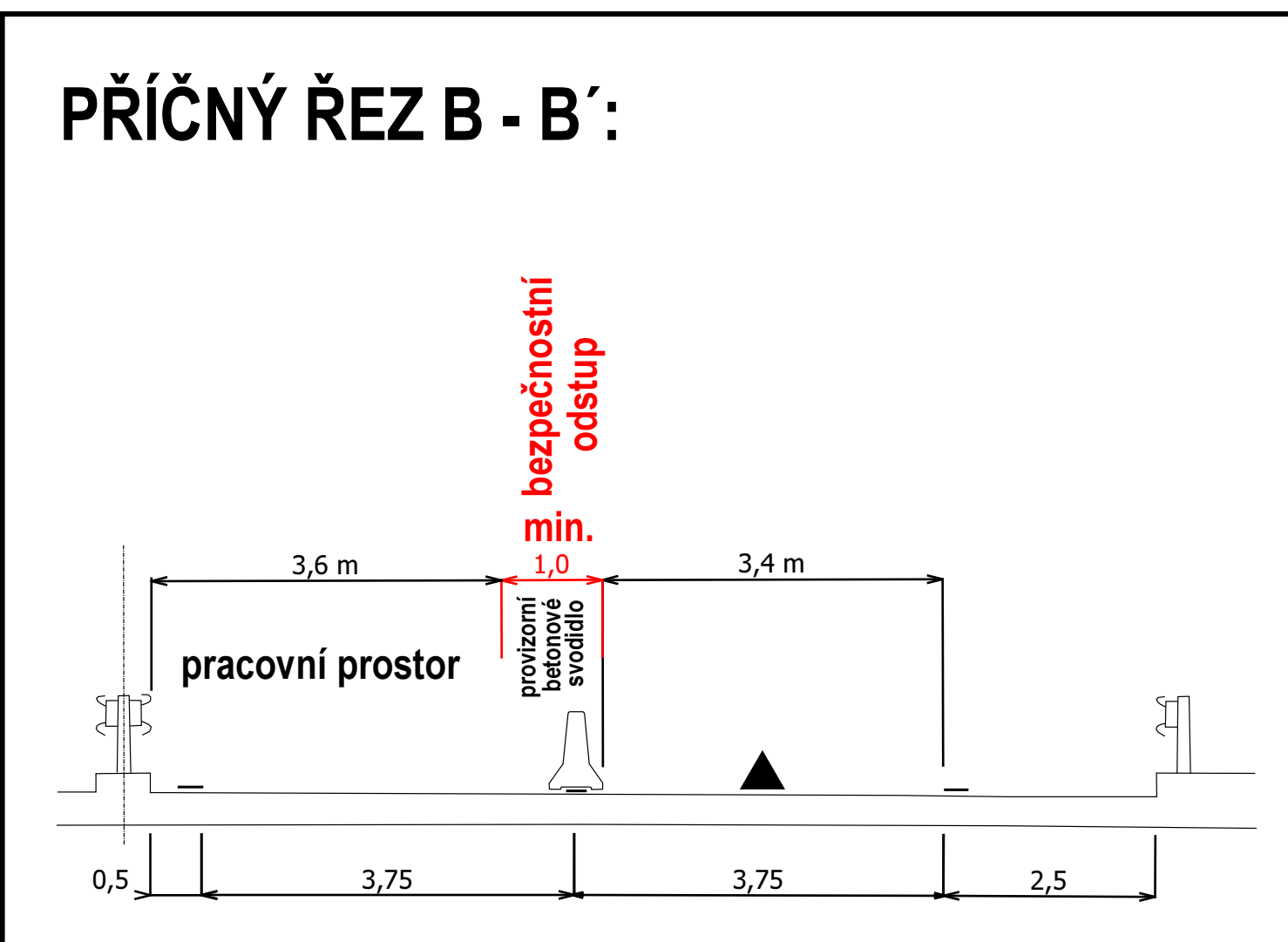
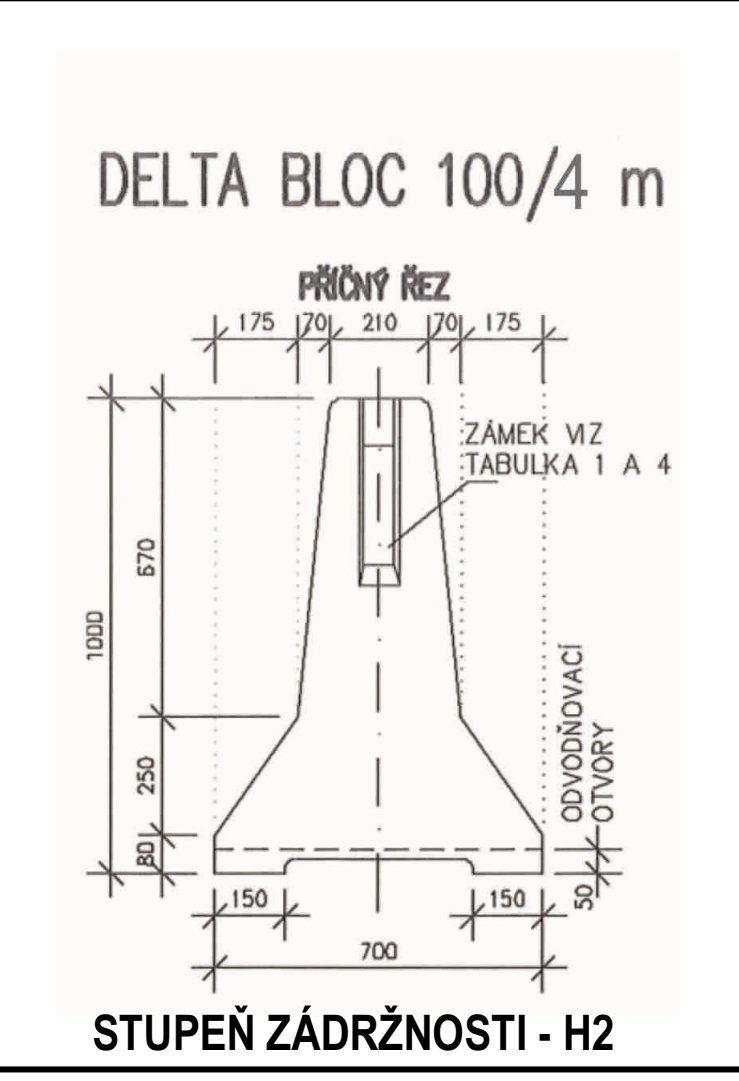
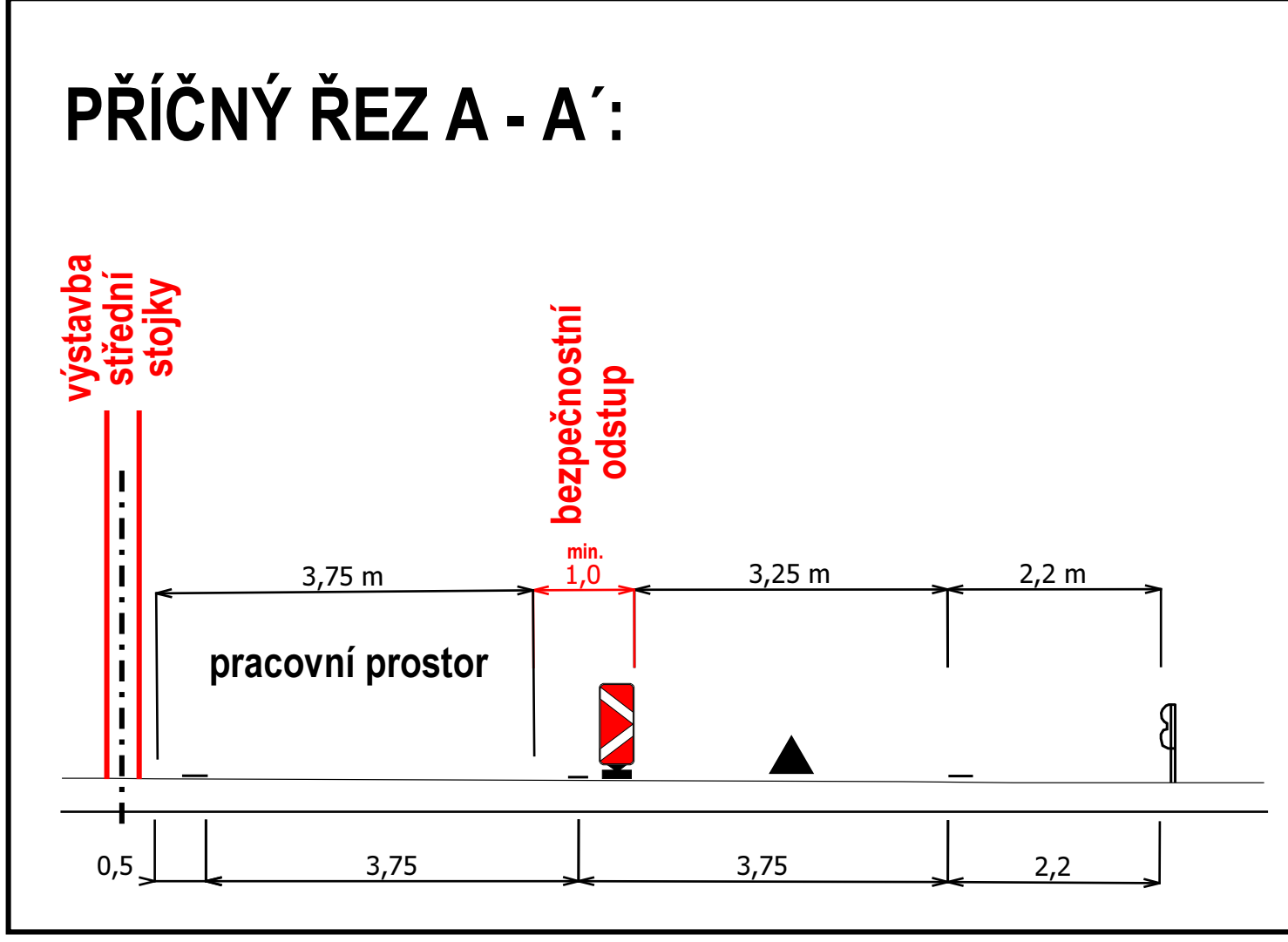

**STAVBA:
OPRAVY MOSTŮ PO DIAGNOSTICKÝCH PRŮZKUMECH 2021,
D6, mosty D6-060..1 a D6-060..2**

**STAVBA:
MODERNIZACE MOSTU
ev. č. 209-011a NOVÉ SEDLO**

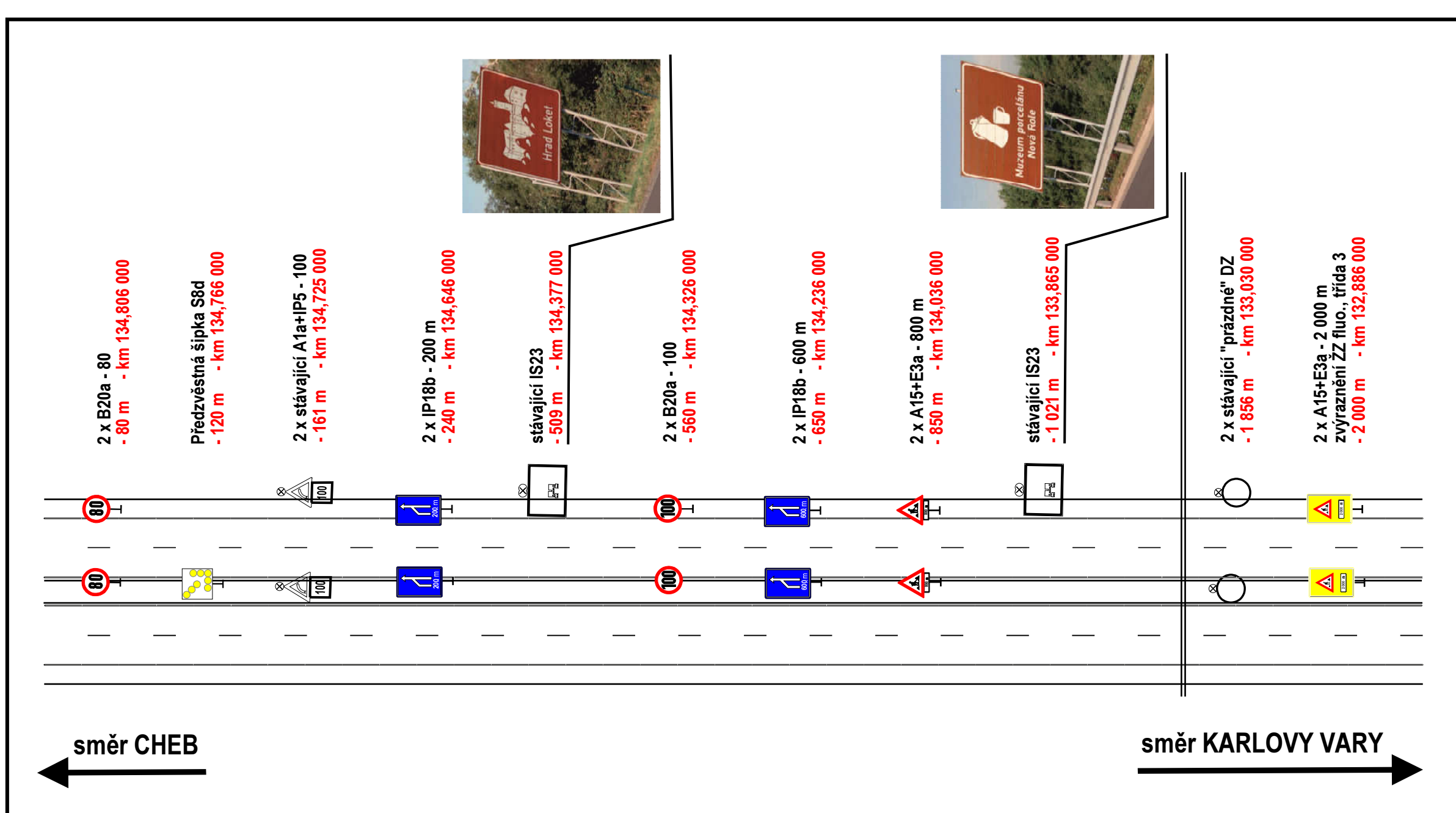
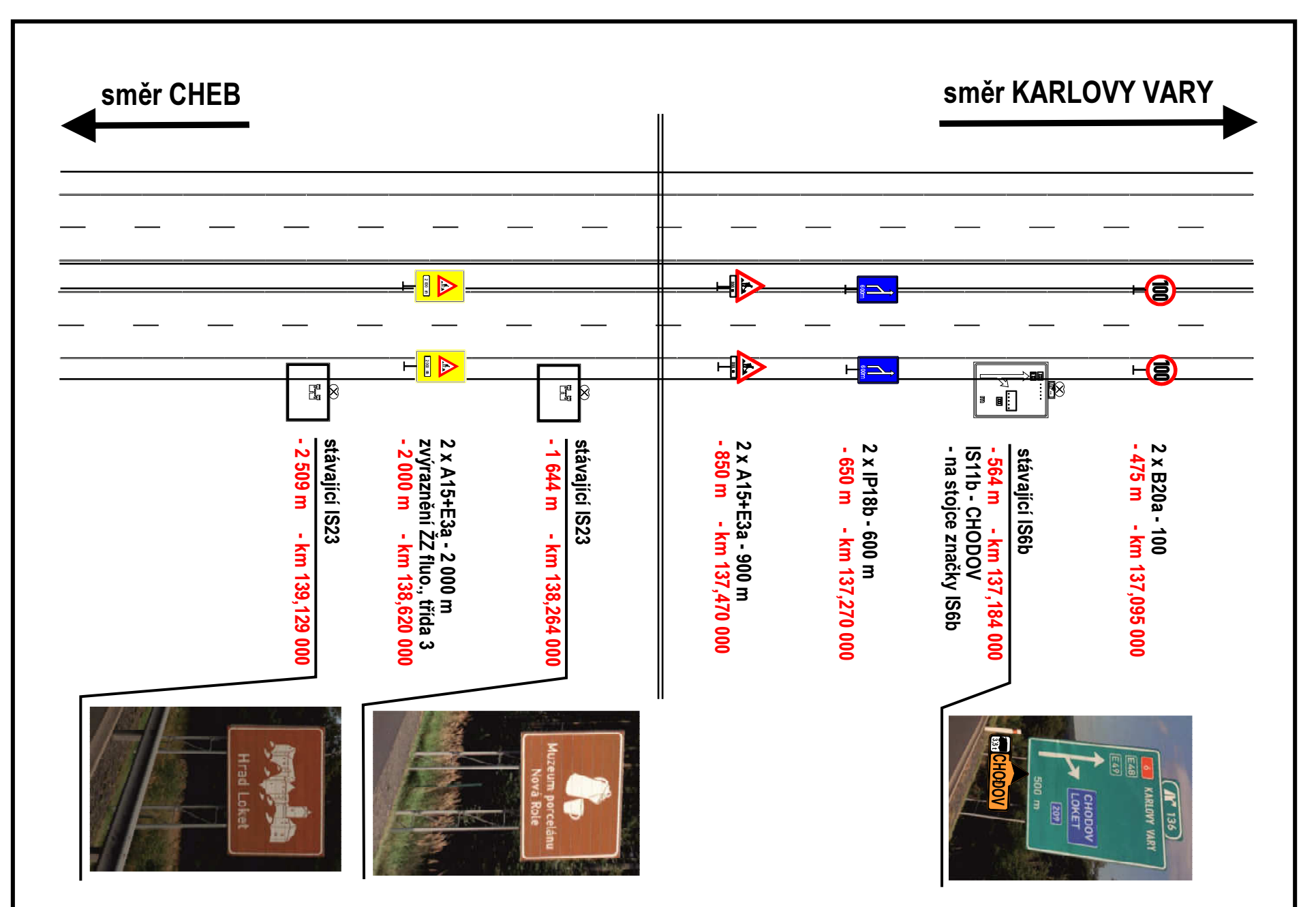


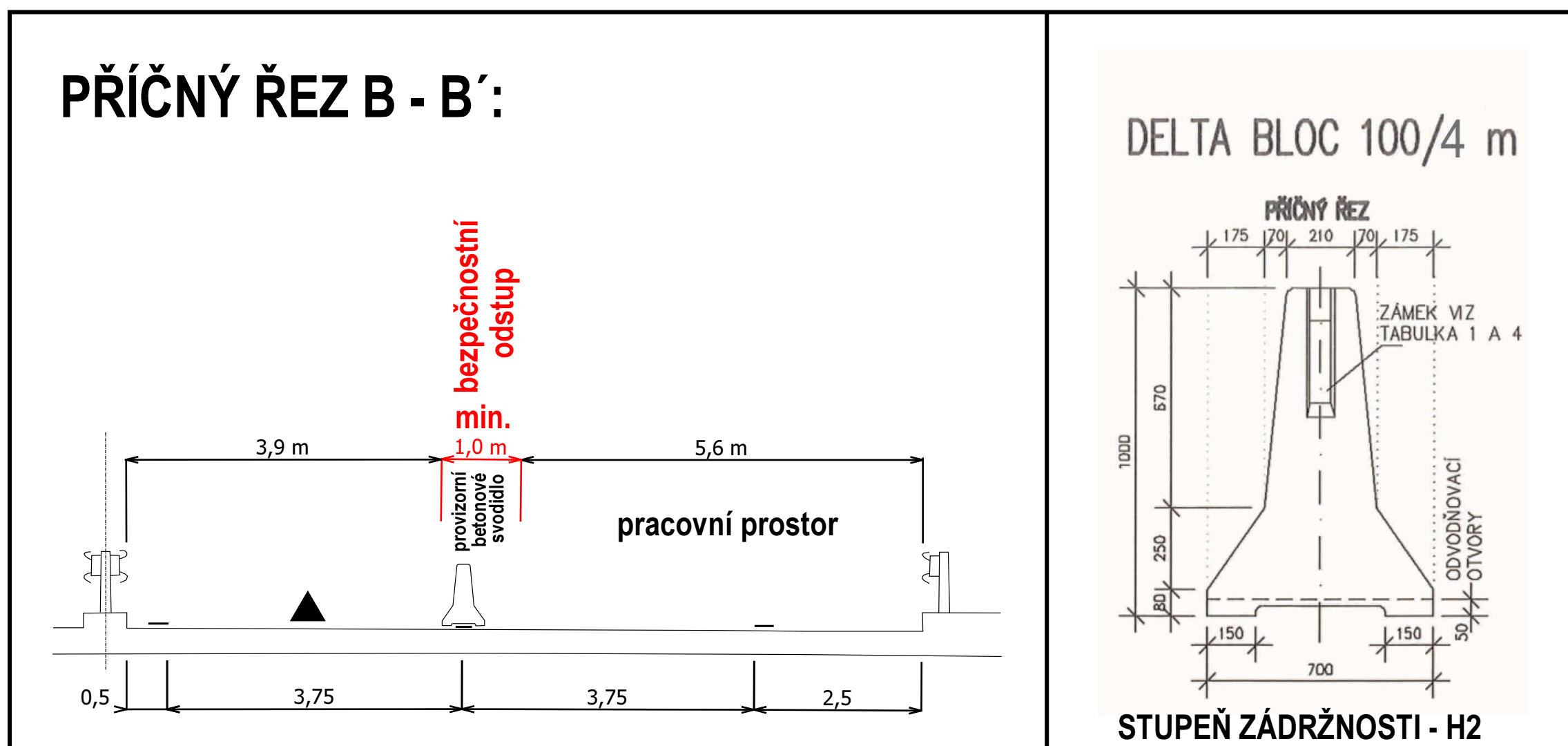
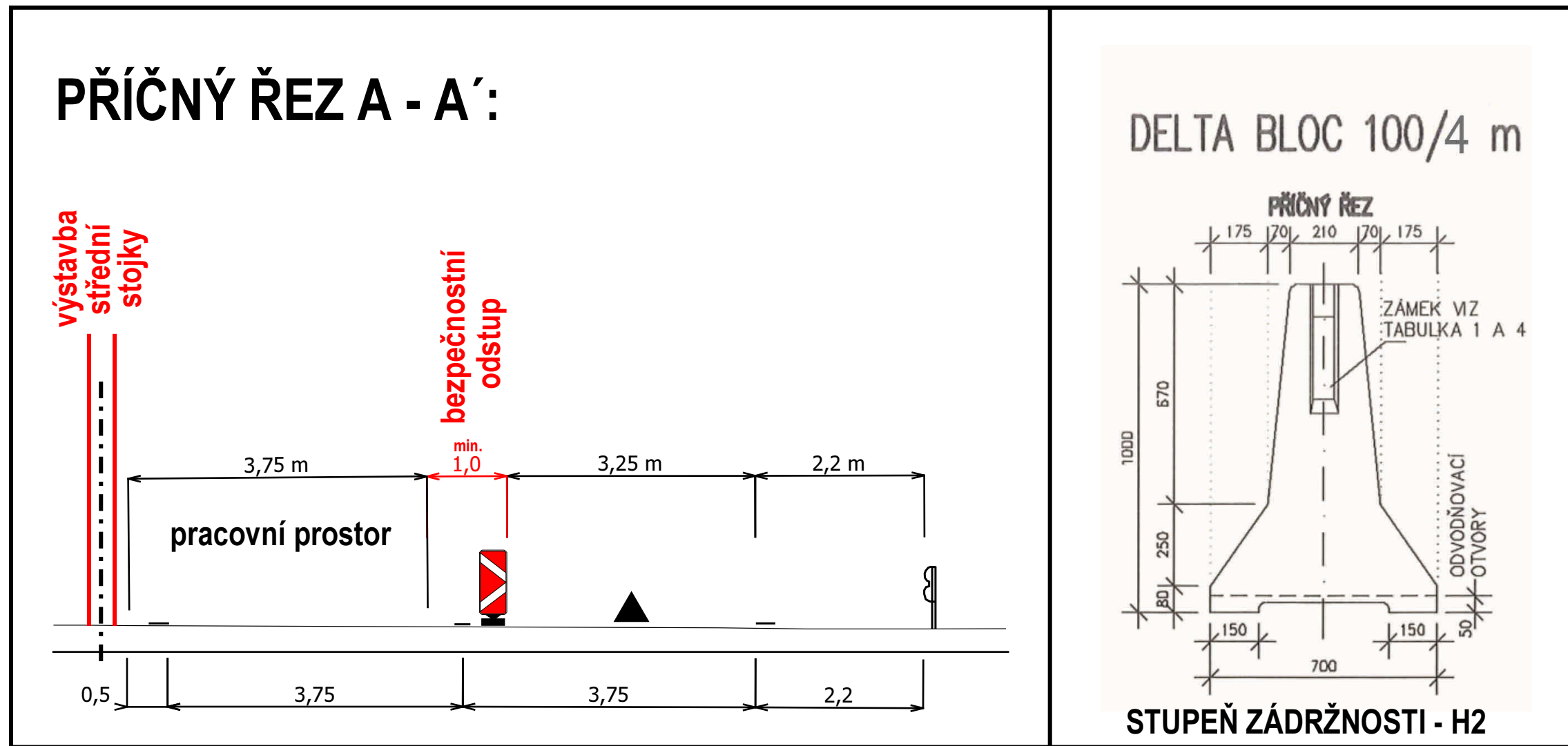

**STAVBA:
OPRAVY MOSTŮ PO DIAGNOSTICKÝCH PRŮZKUMECH 2021,
D6, mosty D6-060..1 a D6-060..2**

**STAVBA:
MODERNIZACE MOSTU
ev. č. 209-011a NOVÉ SEDLO**

